

TRANSMISSION COOLER INSTALLATION INSTRUCTIONS

INSTALLATION REQUIREMENTS:

1. Keep rubber hoses away from sharp edges, hot exhaust pipes, manifolds and/or points of wear.
2. Do not kink hose or bend it tightly. A bend of less than 3" radius will put excessive stress on the hose and cause hose failure.
3. Cooler should be mounted at least 1" from fans and 6" from exhaust manifolds. When mounting to A/C condenser or radiator, foam pads must be used between the cooler and condenser/radiator.
4. Do not overtighten hose clamps. Tighten only until rubber protrudes level with slots in hose clamp. Overtightening can cause hose failure.
5. After 2 weeks, retighten hose clamps to insure against leakage.

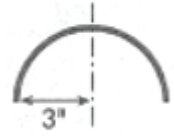

REQUIRED TOOLS:

- Screwdriver or nut driver to attach hose clamps
- Adjustable wrench (or flat wrenches) to remove & replace line fittings
- Knife to cut hose

Average installation time 1/2 hour.

TYPES OF INSTALLATION CONNECTION:

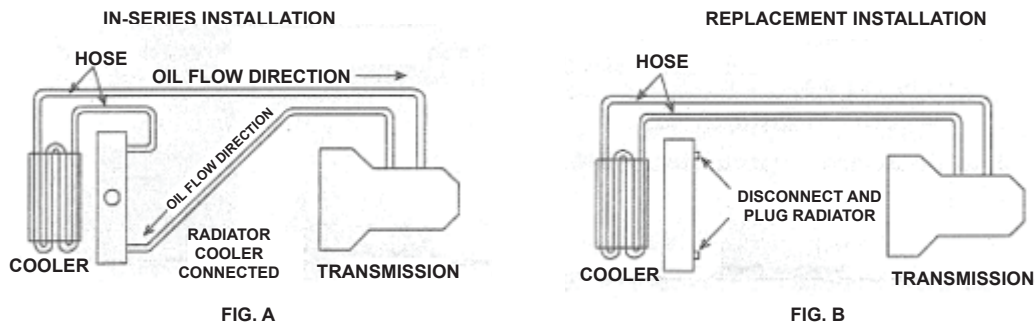

- **In-Series** – The recommended cooler connection is the “in-series” INSTALLATION. It utilizes the existing cooling system and complies with most new car warranties. This method provides maximum cooling by returning the coolest oil directly to the transmission (FIG. A).
- **Replacement** – This method should be used if the existing cooling system is damaged and repair costs are excessive. The replacement installation may void new car warranties and will provide less total cooling than the “in-series” installation. This application requires an oil cooler one or two sizes larger (FIG. B)

RETURN OIL LINE IDENTIFICATION:

Method 1 - Check Oil Line Temperature (FIG. C)

- a. Start engine while engine is cold.
- b. Depress brake pedal, place transmission in drive for no more than 10 seconds
- c. Stop engine
- d. Identify oil return line by feeling both oil lines (3&4). Coolest line is oil return line

Method 2 (requires an observer) – Check Oil Flow Direction (FIG C)

- a. Place container under oil line (3) and disconnect oil line (3). CAUTION- use back-up wrench to avoid damage to radiator fitting.
- b. Start engine, depress brake pedal, place shift selector in drive position.
- c. Stop engine.
- d. Identify direction of oil flow. Oil should flow from cooler in radiator for proper in-series connection.
- e. If oil flowed from radiator fitting, install Quick-Connect adapter in radiator. If Quick-Connect adapter does not fit radiator fitting, refer to selection below.

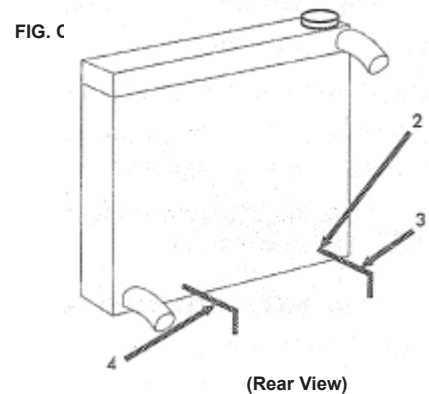

TRANSMISSION OIL COOLER FITTING IDENTIFICATION:

Several O.E. applications have transmission lines that are not compatible with the provided Quick-Connect fitting. Visit www.haydenauto.com for fitting kits by application.

COOLER MOUNTING POSITIONS:

Note: Cooler may be mounted horizontally or vertically. The oil cooler relies upon air flow for cooling.

Shown are the three suggested locations for the cooler in relation to air conditioner condenser and radiator.

#1 Position - 100% efficient (in front of air conditioner condenser)

#2 Position - 75% efficient (in front of air conditioner condenser and radiator)

#3 Position - 60% efficient (between radiator and fan)

Insure selected mounting position complies with installation requirements 1-5.

Double check the position of the hoses to insure that they do not contact the exhaust system or interfere with moving parts. Bend in hose should not be less than **3" radius**.

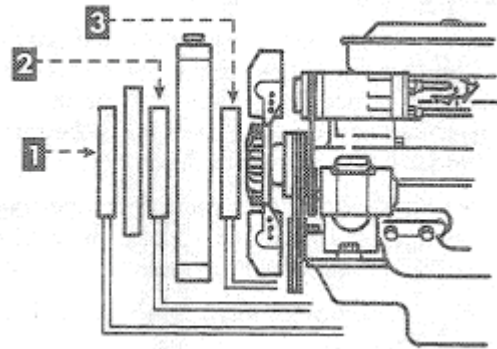

COOLER INSTALLATION:

1. Place clamps on ends of hose and push hose onto oil cooler fitting. Using a couple of drops of trans fluid, lubricate the fittings. Leave hose in loop- **DO NOT CUT THE HOSE**.
2. Position clamps 1/4- 3/8 inch from end of hose. Tighten clamps until rubber protrudes level with clamp slots. **DO NOT** over tighten clamps (Maximum 25 inch pounds torque). (FIG 1)
3. If mounting oil cooler behind radiator position #3 (FIG. D), loosen fan shroud. Cut or drill hole in fan shroud for hose clearance
4. A) Remove adhesive backing from foam pads. B) Plate and Fin Cooler- position holes in pad over holes in cooler mounting flange. (FIG. 2) Tube and Fin Cooler – attach pads to oil cooler. (FIG. 3)
5. Position oil cooler in desired mounting location with pads facing radiator or air conditioning condenser (FIG. 4). Insert rods through cooler and pads, radiator and/or condenser.

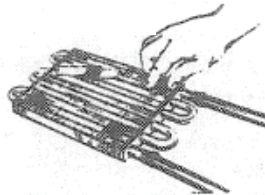
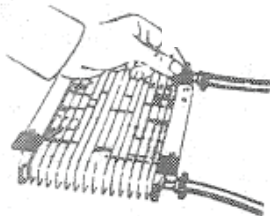
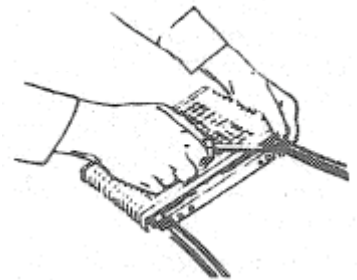

6. Install locking buttons. These are permanent and can only be removed by cutting. Tighten compress the foam pad. Cut off excess mounting rods.
7. Check the installation after a week to check or tighten the mounting rods and for any leaks

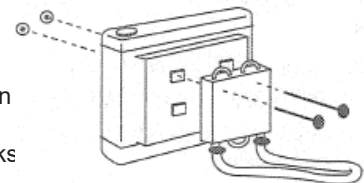

QUICK-CONNECT COUPLER INSTALLATION FOR USE ON VEHICLES WITH 5/16" STEEL LINES:

8. Install Quick-Connect coupler to radiator using appropriate male or female end.
9. Position hose loop next to Quick-Connect fitting and cut hose to length. Slide hose clamps onto hose loosely. Push hose onto Quick-Connect fitting at least one inch.
10. Position remaining hose next to disconnected transmission line and cut hose to length. Hose should be cut to fit at least 1" past flared end. Allow a minimum **3" radius on all hose bends**.
11. Tighten hose clamps.

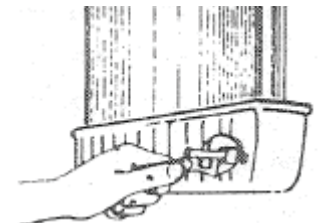

CHECK INSTALLATION AS FOLLOWS:

1. Operate engine at fast idle for 2 minutes. Check hose connections for leakage. If leakage is found, stop engine and tighten clamps.
2. Feel both lines to cooler to be sure they are warm. If both are not warm, oil is not flowing through cooler. Check for kinked lines or other obstructions to flow.
3. Check transmission oil level. Add oil if required. **CAUTION: Do not overfill transmission**

Inspect hoses periodically for hardening and cracking. Use 11/32" I.D. transmission oil cooler hose. **DO NOT** use fuel line. If replacement or additional hose is required, use transmission cooler replacement hose or equivalent. Hose must withstand a minimum 150 psi working pressure and 250°F temperature.