

FAN CONTROLLER INSTALLATION PROCEDURE

3655, 355

Part Number: 3655 (Radiator fin temperature probe included)
Optional Coolant temperature sending harness
Part Number: 355 (sold separately)

INSTALLATION

CAUTION: Always disconnect the positive battery cable from the battery. The positive battery terminal should be covered or shielded with non-conductive material to prevent accidental contact. Failure to do so can result in fire, vehicle damage, battery explosion, bodily injury (up to and including death).

GENERAL DESCRIPTION:

The Temperature Controlled PWM will operate 12 volt DC electric fans using Pulse Width Modulated (PWM) power that varies the fan speed as cooling is required. This product is intended for use in negative grounding systems only and limited to fan motors that draw less than 24 amps. Should current exceed 30 amps for more than 10 seconds the unit is designed to shut down for self-protection. Should this occur, turning off the vehicle ignition and switching back on will reset it. If the unit continues to shut down from excessive amperage, a lower power fan module may be necessary. The unit features built in EMI suppression to avoid radio interference and includes reverse voltage protection. If using electric fans (Part Numbers: 3670 or 3680 – not included) supplied 10 amp fuse should be installed.

TEMPERATURE ACTIVATION OF THE UNIT:

The temperature setting for the fan engagement is set by adjusting the potentiometer on the side with the 6 wires. The operating range of the unit is from 105 degrees Fahrenheit to 210 degrees Fahrenheit. Turning the screw clockwise sets the fans to operate at a lower temperature and counter clockwise for higher temperature set point. The total range of the potentiometer is only 3/4 of a turn and therefore care should be taken to not force the potentiometer past its limits. Only small adjustments should be made at a time. The unit operates at 60 percent of full power when the set temperature is reached. The unit features a soft start in which the voltage ramps up to the 60 percent gradually over 2 seconds. If the temperature rises 10 degrees over the set point, the unit will provide 100 percent full power to the fans. If the temperature returns to the set point, the unit scales back power to 60 percent. Should the temperature drop 10 degrees below the set limit, the unit will shut off power to the fans to prevent short cycling.

AIR CONDITIONING OPERATION

When power (12 volt DC) is applied to the green wire typically connected to the air conditioning compressor switch (with positive switched power), the unit will command the fans to operate at full speed. This manual override is setup to operate when the clutch engages on the compressor or via a separate switch.

TEMPERATURE PROBE

This unit is designed to receive a signal from one of two harness kit choices for temperature sensing. One option is a probe (included in Part Number: 3655) which inserts into the radiator or condenser fins to read ambient air temperature. The other probe is a male NPT brass plug to be inserted directly into the coolant path (optional Part Number: 355 – NOT INCLUDED).

MOUNTING THE PWM UNIT

The unit should be secured in a location away from moving parts and sources of heat radiation (e.g. exhaust manifolds). The fins on the back of the unit will help the unit cool and should be exposed to some form of open air flow. Failure to mount the unit away from sources of heat can potentially damage the unit and will VOID the warranty.

Typical acceptable locations are near the front of the battery or fuse box in the engine bay or near the radiator fan. Adequate air flow will ensure increased life of the product and more reliable performance. The unit is designed to operate in conditions up to 221 degrees Fahrenheit and 320 watts, but ideal conditions are below 176 degrees Fahrenheit. The unit is designed to operate at full power in the event that electronics approach the upper temperature limit. The PWM is hermetically sealed and water resistant. The unit comes with holes for #8 screws (customer supplied) in the corners or can be secured using the Hayden Quik Mounts®. Part Number: 210 (Sold separately).

PROBE INSTALLATION

The ambient air temperature probe should be installed through the fins of the radiator near the coolant inlet. The optional brass temperature probe is a 1/8 to 27 NPT and should have direct contact with the coolant flow for optimal results.

WIRING

The unit comes with 8 wires to install. The supplied diagram at bottom will reference the number for each location.

TERMINALS #1 & #2 (GREY WIRES) – INPUT SIDE

Terminals #1 & #2 go to the temperature sensor and probe (for either type of probe used). Both terminals need to be installed for the unit to function.

TERMINAL #3 (GREEN WIRE) – INPUT SIDE

Terminal #3 is the manual override from the air conditioning switch. This wire needs to connect to the positive compressor clutch wire or a 12 volt positive switch for manual control. The green wire need not be installed should the user desire only temperature control to operate the fan/fans. Any 12 volt source that is present when the compressor clutch is engaged is acceptable.

TERMINAL #4 (YELLOW WIRE) – INPUT SIDE

Terminal #4 is the ignition supply voltage wire. The unit is designed to continuously monitor coolant temperature while ignition voltage is present. This wire should come from a fused ignition source. Do not install this wire directly to the battery terminal as it could potentially drain the battery.

TERMINAL #5 (RED WIRE NEAR 4 SMALLER WIRES) – INPUT SIDE

Terminal #5 is the main 12 volt supply wire. It should be installed directly to the battery and protected with the included 25 amp fuse. The unit is designed to operate anytime the battery has more than 9.5 volts. The unit will shut down if voltage exceeds 21 volts. Install a 10 amp fuse if 10 & 12 inch electric fans (Part Numbers: 3670 or 3680) are used.

TERMINAL #6 (BLACK WIRE NEAR 4 SMALLER WIRES) – INPUT SIDE

Terminal #6 is the main grounding wire. This wire should go to a good chassis ground or the negative terminal of the battery.

TERMINAL #7 (BLUE WIRE FURTHEST FROM THE 4 SMALLER WIRES) – OUTPUT SIDE

Terminal #7 is the motor positive supply wire. On Hayden fan modules this is the black wire when pusher orientation is desired.

TERMINAL #8 (BLACK WIRE FURTHEST FROM THE 4 SMALLER WIRES) – OUTPUT SIDE

Terminal #8 is the motor negative supply wire. On Hayden fan modules this is the blue wire when pusher orientation is desired.

Should the fan need to run the opposite direction (puller orientation) terminals #7 and #8 can be reversed.

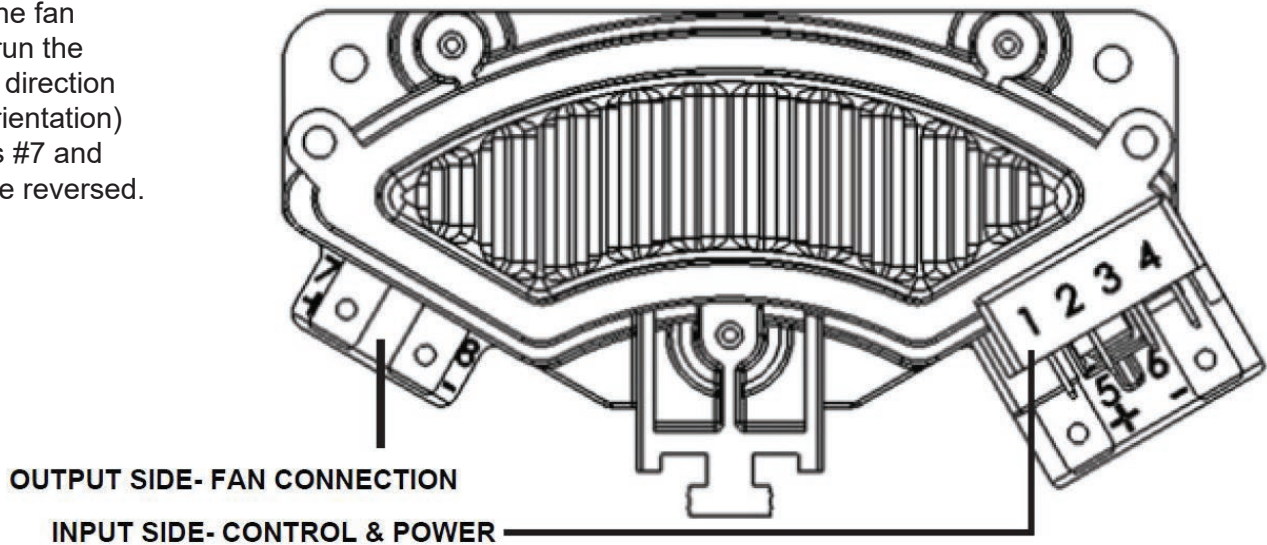

Diagram of PWM.

Output Side - Fan Connection
Input Side - Control & Power

TROUBLE SHOOTING GUIDE

Issues	Potential Cause	Remedy
Fans are not running regardless of temperature.	<ol style="list-style-type: none"> 1. The ignition is off. 2. The battery is not properly connected. 3. The Probe temperature has not reached the set point. 4. The Current exceeds 30 amps for more than 10 seconds. 5. The Electronics ambient temperature exceeds 105 degrees Celsius (212 degrees Fahrenheit). 6. The temperature probe is not connected properly. 7. Fuse is blown. 	<ol style="list-style-type: none"> 1. Check that the key is on and there is positive signal on terminal #4. 2. Check battery positive is connected to the #5 terminal and that the unit is properly grounded to terminal #6. 3. Turn the blue potentiometer CW to lower the ON temperature. 4. Check current at the fan with a clamp on current probe. If the current exceeds 30 amps for more than 10 seconds the PWM will self-protect and power down. The fan has exceeded the acceptable power rating of the PWM and must select a lower power fan module. 5. Move the electronics to a cooler location 6. Put a positive 12 volt signal to terminal #3 to see if the PWM can be switched on. 7. Check the fuse and replace.
Fan Runs Full Speed all the time.	<ol style="list-style-type: none"> 1. There is always a positive signal to terminal #3 from the AC clutch. 2. The PWM set point is too low or the temperature has exceeded the set point by more than 10 degrees Fahrenheit. 3. The PWM electronics ambient temperature is between 100 degrees Celsius and 105 degrees Celsius, and the PWM is running at full speed to self-cool. 	<ol style="list-style-type: none"> 1. Check the speed of the fan with a tachometer to ensure that the fan speed is not changing. Remove the wire from terminal 3 and check. If this signal is always 12 volt positive, find another wire from the HVAC systems that is only positive 12 volt when the AC is ON. 2. Increase the set point by dialing the potentiometer CCW. 3. Move the PWM electronics to a cooler location.
Fan runs backwards.	Motor leads are not properly connected.	Switch the motor leads on terminals #7 & #8. A fan in the engine bay behind the radiator should pull the air through the radiator/cooler. A fan mounted on the front of the vehicle on the bumper side should push air through the radiator.
PWM and Fan run after the vehicle ignition is switched off or the vehicle battery is draining.	A positive signal is on terminal 4 at all times.	Connect terminal #4 to a 12 volt positive wire that is only ON when the ignition is turned ON.

Issues	Potential Cause	Remedy
Fans only come ON when the temperature is very hot.	<ol style="list-style-type: none"> 1. The temperature probe is not located in an ideal location. 2. The set point of the PWM is too high. 	<ol style="list-style-type: none"> 1. The set point of the PWM is too high. 2. Turn the blue potentiometer screw CW to lower the ON temperature.
The engine is cold and the fan comes ON.	<ol style="list-style-type: none"> 1. Temperature probe is in a location that is too hot. 2. AC is turned on. 3. Fan is turned on in defrost mode (some vehicles). 4. PWM set point is too low. 	<ol style="list-style-type: none"> 1. Move the temperature probe closer to the radiator outlet hose. 2. Turn off AC or remove signal to Terminal #3. 3. Change mode from Defrost or remove signal to Terminal #3. 4. Turn the blue potentiometer screw CCW to raise the ON temperature.
Temperature settings are not staying.	Temperature settings are not staying.	Apply a small drop of glue to the top of the potentiometer to prevent movement due to vibration once set.