

ELECTRIC FAN INSTALLATION PROCEDURE

36895, 36896, 36897, 36898, 37105

NOTE: Please read these instructions carefully before installing fan(s) to ensure a safe and easy installation. These instructions are for 12-volt negative ground vehicles. The fans will operate on positive ground vehicles if the indicated polarity is reversed. They can be used on 6-volt systems but will operate at a reduced speed.

Each fan is supplied with one of two types of mounting brackets:

Type 1 uses brackets that must be inserted into the shroud. It will have these mounting parts:

- 4 Fan mounting brackets
- 4 Conical springs
- 4 Foam pads
- 4 Black mounting rods
- 4 Black lock buttons

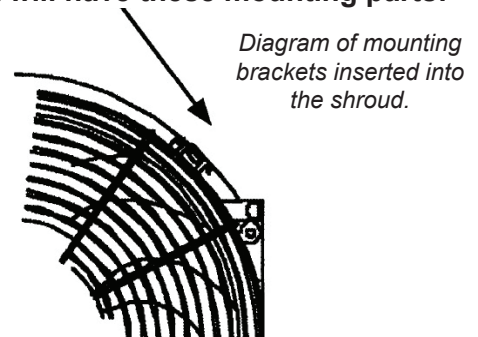

Type 2 uses brackets that are molded into the shroud. It will have these mounting parts:

- 4 Conical springs
- 4 Foam pads
- 4 Black mounting rods
- 4 Black lock buttons

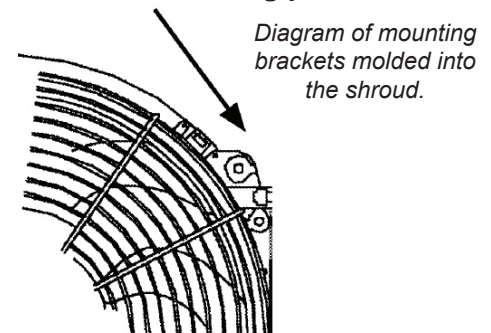

Required Tools

- Flat blade screwdriver
- Pliers
- Wire stripper/crimper

INSTALLATION

1. Disconnect positive battery cable.

Replacement Installation for Belt Driven Fan:

- 2A. Remove fan clutch assembly and fan shroud.
- 2B. Attach the pulley to the water pump flange. If necessary, use shorter bolts to clear the water pump housing. Failure to properly secure the pulley may result in personal injury or damage to the vehicle.

Replacement Installation for Original Equipment Electric Fan:

These fans have single speed motor and are not compatible with all original equipment manufacturers. Fan controls that use more than two wires.

- 3A. Detach all wires to existing electric fan.
- 3B. Remove electric fan assembly.

Add-On Installation:

- 4A. Measure the distance in front of the radiator A/C condenser to the grill.
- 4B. Measure the distance behind the radiator to the fan blades or closest engine component.
- 4C. Choose whether to install the fan(s) as a pusher(s) (in front of the radiator) or as a puller(s) (behind the radiator) based on the available room.

NOTE: At least 1" clearance is needed between the fan and other vehicle components.

These fans are assembled as pushers. To convert the fan to a puller it is necessary to both reverse the blade and reverse the wiring.

Pusher Installation (in front of radiator):

Go to steps 6-7.

Puller Installation (behind the radiator):

- 5A. Remove the fan blade retaining clip or nut.
- 5B. Carefully remove the fan blade retaining clip or nut.
- 5C. Turn the blade over, align the groove in the blade with blade with the roll pin in motor shaft and carefully push the blade onto the shaft.
- 5D. Reinstall the retaining clip or nut on the motor shaft.

NOTE: It is usually not necessary to remove the radiator to install the electric fan(s). On some vehicles, it may be necessary to remove the mounting hardware and tilt the radiator back towards the engine to gain access between the radiator and the AC condenser.

Fan Mounting Hardware:

- 6A. For fans supplied with separate mounting brackets (Type 1), insert the four mounting bracket into the slots on fan.
- 6B. Remove paper backing from the foam pads and apply the pads to the bottom of four bracket. Trim off access foam to avoid interference with the fan blades.
- 6C. Slide the small end of the conical springs onto the mounting rods.
- 6D. Place the fan assembly in the desired position on the radiator or AC condenser.
- 6E. Carefully, push the mounting rod through the holes in the brackets on the radiator or AC condenser. Do not insert the rods through both the radiator and AC condenser
- 6F. Push the lock buttons over the ends of the mounting rods. Pull the rods through the buttons until the springs are 1/2 the original height. Trim the excess rod. (See Fig. A)
- 6G. Before wiring, spin the fan blade to ensure free rotation.

CAUTION: TAKE CARE TO NOT PUNCTURE THE RADIATOR OR CONDENSER TUBES. DO NOT INSERT THE RODS THROUGH BOTH THE RADIATOR AND THE CONDENSER.

Electric Wiring Installation:

NOTE: REFER TO THE LABEL ON THE SHROUD TO DETERMINE THE POSITIVE WIRE FOR PUSHER FANS. FOR PULLER FANS, THE WIRE POLARITY MUST BE REVERSED IN ADDITION TO REVERSING THE BLADE AS DESCRIBED IN 5A – 5D.

Installation with a Fan Control:

Refer to the wiring instructions enclosed with the fan control kits.

Installation without a Fan Control:

- 7A. Disconnect the positive battery cable to prevent accidental starting of the fan.
- 7B. Connect the negative fan wire to the ground. Connect the positive wire to a switch rated to 25 amps (not included). Connect the switch through 25 amp fuse to a positive (+) 12 volt source. (See Fig. B)
- 7C. Reconnect positive battery cable.
- 7D. Start the engine and check the fan for proper operation. The fan should push or pull the air through the radiator toward the engine.

FIGURE "A"
Diagram of mounting hardware.

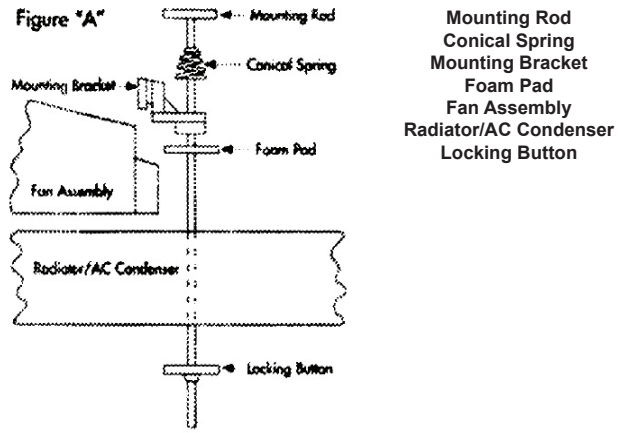

FIGURE "B"
Wiring diagram.

